

The Development of Tuberculosis Treatment Room in Humid Tropical Climate

Wisdom Sandjaya Papendang¹, Samuel Yudhatama²

¹ Trinita Widi Anoma - Architecture Consultant, Indonesia

² Universitas Atma Jaya Yogyakarta, Indonesia

Article Info

Article history:

Received March 28th, 2022

Revised April 27th, 2022

Accepted May 27th, 2022

Keywords:

CFD

Tuberculosis

Nosocomial

Treatment Room

ABSTRACT

Developing countries with a humid tropical climate, such as Indonesia, still have a severe problem with Tuberculosis (TB). Mycobacterium tuberculosis (MTB) mainly causes TB and is transmitted through droplets released by active TB patients into the air that progress faster in humid tropical climates. Health workers are at high risk of contracting TB bacteria from TB patients because nosocomial infections (healthcare-associated infections) categorize as TB. Public Health Centers usually provide generic rooms but are not explicitly designed to minimize TB infections. The Indonesian government does not offer a TB treatment room design, so this research developed a Tuberculosis Treatment Room (TBTR) prototype using a computational fluid dynamics simulation. The TBTR prototype was split into medicine and sputum room. The simulation showed that the TBTR's air change per hour was between 77 and 94, far above the minimum standard of 12. In addition, TBTR showed indoor air 80cm above the floor flowed upward and out through the ceilings, while indoor air below 40cm above the floor flowed through lower openings. Those ventilation mechanisms expelled the indoor bacteria out and minimized infection.

Corresponding Author

Wisdom Sandjaya Papendang,

Trinita Widi Anoma - Architecture Consultant, Perum. Pesona Ketingan Kav. B1 RT/RW.01/20, Tirtoadi, Mlati, Sleman, Yogyakarta, Indonesia

Email: wpapendang@gmail.com

1. INTRODUCTION

Indonesia is a developing country with serious health problems, one of which is Tuberculosis (TB). PPM (The public-private-mix) has strengthened the care and control of Tuberculosis in many countries. However, Indonesia, despite the implementation of PPM in 2003, still has a low TB case awareness rate [1]. TB still cannot be eradicated even though the medical world has discovered anti-tuberculosis drugs and implemented the Bacillus Calmette - Guérin (BCG) vaccination [2]. The risk of disease transmission in health facilities is much more significant when compared to that occurring in the community. TB transmission is also a nosocomial infection, an infection transmitted while in a hospital or specific health facility. TB is a disease caused by work or occupational diseases for health workers.

Until now, not all health service facilities have implemented adequate TB prevention, especially at first-level health facilities such as *Puskesmas* (Pusat Kesehatan Masyarakat, Public Health Center). Only big hospitals provide standardized Tuberculosis treatment rooms. At the *Puskesmas*, TB treatment is carried out by general practitioners with the assistance of the *Puskesmas* laboratory to observe TB patients. Most of the existing TB care rooms in *Puskesmas* in Indonesia are inadequate, so there is still a high risk of TB disease transmission in these facilities. Indoor TB bacteria must be exposed to direct sunlight as soon as possible; therefore, maximum indoor air change is the primary key in TB treatment rooms. The critical location for TB care rooms must fulfill the need for top air change. In humid tropical climates, some conditions are pretty

typical, namely the state of no wind. The no wind condition is where the wind speed reaches 0 m/s, which in turn causes no movement and air change in an environment. The state of no wind is dangerous for infectious spaces because it causes the air inside to stop changing so that bacteria such as TB bacteria can last longer in a room. Therefore, a prototype for Tuberculosis Treatment Room (TBTR) patient care in health facilities such as *puskesmas* (stands for *pusat kesehatan masyarakat*, public health center) is needed to reduce the transmission and spread of TB disease in humid tropical climates efficiently and effectively.

Previous studies involving TB showed positive changes in their respective topic and place; for example, a community-based knowledge and behavior improvement on Flores shows improved early case identification [3]. A study that developed new policies in handling TB shows an improvement even though it has limited sustainability [4]. Another study focused on improving human resources, which spectacularly affects the case detection and treatment outcome [5]. Research focuses on mistreatment among TB patients, resulting in more effective treatment [6]. Lost as high as 43.5% of 754 TB suspects during the diagnostic in a health center in Yogyakarta [6]. None of those studies directly discuss any TB treatment room.

1.1. Tuberculosis

Mycobacterium tuberculosis (MTB) mainly causes TB, a small, non-motile aerobic bacillus. The high fat/lipid content of MTB causes MTB pathogens to have unique clinical characteristics. MTB can withstand a weak range of disinfectants and can survive dry conditions for weeks. MTB bacteria have a different bacterial wall composition compared to other bacteria. MTB is an Acid-Resistant Basil (BTA) category, known for its main characteristic, acid resistance, compared to other bacterial bacilli [7]. BTA means that MTB results are not easily killed by acids such as H_2SO_4 . As a result, MTB includes bacteria that are difficult to control.

The MTB bacilli infection often occurs by inhalation, transmitting MTB bacilli through breathing, coughing, sneezing, talking, spitting, and even singing. MTB bacilli travel through the air through droplets from people with active TB. Several factors influence the possibility of Tuberculosis transmitted from one person to another; these factors include the number of infectious droplets released by TB patients in droplets containing MTB [8]. TB transmission is a nosocomial infection that develops in a hospital where transmission originates from certain hospitals or health facilities through direct or air contact.

A Tuberculosis patient who does not get proper treatment can infect 10-15 (or more) people each year [9]. Tuberculosis transmission often occurs in crowded places with inadequate ventilation facilities, such as hospitals, clinics, prisons, and refugee camps [10]. Health workers fall at a high risk of contracting Tuberculosis [8]. The risk of TB transmission to health workers increases with the intensity of direct contact between active TB patients and nurses serving TB patients [11]. MTB bacilli live well in a humid environment but are not resistant to sunlight [12]. MTB bacillus is 1-4 μm long and 0.2-0.8 μm wide. These bacteria float in the air and are called droplet nuclei [13]. According to Atmosukarto (2000), MTB bacillus can survive in a cool, damp, dark place without sunlight for years. Still, MTB bacillus will die when exposed to sunlight, soap, Lysol, carbolic acid, and flame [14].

1.2. Tuberculosis Treatment

Through the Ministry of Health, the government of Indonesia has made various efforts since the Ministry of Health reported the first TB case to issue Ministerial Regulation number 67 of 2016 concerning Tuberculosis Control. It has further regulated the treatment of TB patients to a minor level, namely at the *puskesmas*. TB treatment by the DOTS (Directly Observed Treatment Shortcourse) team at the hospital is responsible for initiating the Tuberculosis Control program. Tuberculosis treatment is carried out directly in each health facility, from the health center to the hospital. Tuberculosis treatment is carried out directly in every health facility, from *Puskesmas* to hospitals, using the acid-fast bacillus (AFB) application method and the X-ray method that targets the patient's chest as an identification process [15]. To cure, Tuberculosis can use anti-tuberculosis drugs regularly to consume anti-tuberculosis drugs. TB patients must come to the nearest health facility to get anti-tuberculosis medicines and take them immediately accompanied by a health worker. Ordinary TB can increase to MDR-TB (Multi-Drug Resistance - Tuberculosis) or Tuberculosis with resistance to anti-tuberculosis drugs if the patient does not take anti-tuberculosis medicines regularly.

1.3. Anthropometry

Anthropometric data is needed to design a better system, the physical environment inside the workplace. Developing a working system with an anthropometric approach produces a physical environment

directly or indirectly affecting space workers/users. Generally, anthropometry deals with body size (width, height, thickness) and head, body, and feet dimensions. Several dimensions are the scope of anthropometric measurements (reported from anthropometriindonesia.org). The TB care room must optimally accommodate all patients' and health workers' activities. Hartono stated that Asia, especially Indonesia, has anthropometric data quite different from other populations. The following is anthropometric data from the Indonesian people as a reference for developing TBTR [16].

Table 1. Anthropometric Data of Indonesian People
Source: Hartono [16]

| Dimension | Elderly | | | | p | Female | | | | p |
|------------------------------------|---------|-------------|-------|------|------|---------|-------------|-------------|------|-------------|
| | Male | | | | | Chinese | | non-Chinese | | |
| | Chinese | non-Chinese | | | | Chinese | non-Chinese | | | |
| | 50th | SD | 50th | SD | | 50th | SD | 50th | SD | |
| 1. Stature | 159.9 | 11.9 | 158.9 | 12.7 | 0.47 | 153.5 | 15.0 | 149.7 | 15.5 | 0.04 |
| 2. Eye height | 148.6 | 12.5 | 148.0 | 13.0 | 0.65 | 139.8 | 15.7 | 137.9 | 15.1 | 0.22 |
| 3. Shoulder height | 130.8 | 11.1 | 130.3 | 11.3 | 0.64 | 114.4 | 13.9 | 113.7 | 13.5 | 0.45 |
| 4. Elbow height | 97.1 | 6.9 | 98.5 | 6.5 | 0.48 | 91.2 | 10.6 | 93.0 | 10.7 | 0.18 |
| 5. Hip height | 89.7 | 7.4 | 90.4 | 7.3 | 0.43 | 84.4 | 10.8 | 82.9 | 11.2 | 0.12 |
| 6. Knuckle height | 67.8 | 6.3 | 68.2 | 6.1 | 0.45 | 63.7 | 8.9 | 63.3 | 7.7 | 0.56 |
| 7. Fingertip height | 59.0 | 5.9 | 58.7 | 5.8 | 0.45 | 55.7 | 8.7 | 55.7 | 8.3 | 0.81 |
| 8. Sitting height | 79.5 | 6.7 | 78.9 | 6.5 | 0.56 | 66.5 | 11.7 | 66.7 | 12.3 | 0.58 |
| 9. Sitting eye height | 65.7 | 6.8 | 65.9 | 6.5 | 0.64 | 59.8 | 9.8 | 59.0 | 10.1 | 0.62 |
| 10. Sitting shoulder height | 54.4 | 6.8 | 53.1 | 6.3 | 0.44 | 48.3 | 7.7 | 48.4 | 7.7 | 0.91 |
| 11. Sitting elbow height | 23.4 | 5.2 | 22.8 | 5.3 | 0.45 | 18.1 | 5.6 | 18.6 | 6.1 | 0.51 |
| 12. Thigh thickness | 15.1 | 2.9 | 14.9 | 3.2 | 0.51 | 12.6 | 3.7 | 12.5 | 3.9 | 0.76 |
| 13. Buttock-knee length | 57.7 | 4.2 | 57.5 | 4.0 | 0.81 | 54.3 | 7.6 | 54.5 | 7.5 | 0.78 |
| 14. Buttock-popliteal length | 48.6 | 4.5 | 48.3 | 4.4 | 0.84 | 45.8 | 5.9 | 45.8 | 5.7 | 0.89 |
| 15. Knee height | 54.8 | 4.6 | 54.5 | 4.6 | 0.56 | 52.9 | 6.1 | 51.9 | 6.1 | 0.14 |
| 16. Popliteal height | 42.2 | 4.8 | 41.6 | 4.6 | 0.42 | 41.9 | 5.7 | 42.1 | 5.2 | 0.23 |
| 17. Shoulder breadth (bideltoid) | 46.9 | 5.3 | 46.4 | 5.1 | 0.51 | 41.2 | 7.9 | 40.6 | 8.2 | 0.18 |
| 18. Shoulder breadth (biacromial) | 35.6 | 4.3 | 35.0 | 4.2 | 0.52 | 33.0 | 6.6 | 33.3 | 6.8 | 0.58 |
| 19. Hip breadth | 45.5 | 6.7 | 44.9 | 6.4 | 0.44 | 43.5 | 8.0 | 43.4 | 7.8 | 0.61 |
| 20. Chest (bust) depth | 25.3 | 6.0 | 25.7 | 6.3 | 0.51 | 22.7 | 7.1 | 23.1 | 7.2 | 0.59 |
| 21. Abdominal depth | 28.6 | 7.7 | 28.4 | 7.7 | 0.62 | 28.1 | 9.8 | 28.6 | 9.3 | 0.64 |
| 22. Shoulder-elbow length | 33.9 | 3.1 | 33.4 | 3.5 | 0.48 | 30.0 | 4.6 | 29.6 | 5.0 | 0.24 |
| 23. Elbow-fingertip length | 44.4 | 3.9 | 44.6 | 3.7 | 0.51 | 38.5 | 6.7 | 38.7 | 6.4 | 0.56 |
| 24. Upper limb length | 70.4 | 6.0 | 71.0 | 5.9 | 0.39 | 65.9 | 6.5 | 67.1 | 6.9 | 0.16 |
| 25. Shoulder-grip length | 54.5 | 3.2 | 54.6 | 3.4 | 0.61 | 49.5 | 6.1 | 49.9 | 5.9 | 0.54 |
| 26. Head length | 18.5 | 2.2 | 18.6 | 2.3 | 0.58 | 18.4 | 3.3 | 17.8 | 3.3 | 0.43 |
| 27. Head breadth | 22.2 | 2.9 | 22.3 | 2.9 | 0.75 | 20.6 | 4.2 | 20.4 | 4.2 | 0.78 |
| 28. Hand length | 20.1 | 1.4 | 19.9 | 1.3 | 0.56 | 17.6 | 4.0 | 17.2 | 3.8 | 0.68 |
| 29. Hand breadth | 10.4 | 1.6 | 10.2 | 1.7 | 0.74 | 10.6 | 2.3 | 10.5 | 2.3 | 0.78 |
| 30. Foot length | 24.8 | 2.4 | 24.9 | 2.5 | 0.76 | 22.3 | 3.4 | 23.0 | 3.5 | 0.41 |
| 31. Foot breadth | 11.3 | 1.6 | 11.5 | 1.6 | 0.71 | 10.7 | 1.9 | 11.0 | 2.0 | 0.38 |
| 32. Span | 154.3 | 14.9 | 153.2 | 14.9 | 0.62 | 143.9 | 16.3 | 144.1 | 16.9 | 0.57 |
| 33. Elbow span | 75.7 | 7.7 | 75.4 | 7.3 | 0.68 | 72.8 | 8.2 | 72.8 | 7.6 | 0.79 |
| 34. Vertical grip reach (standing) | 193.4 | 21.4 | 193.5 | 20.9 | 0.54 | 191.8 | 24.4 | 184.4 | 26.0 | 0.01 |
| 35. Vertical grip reach (sitting) | 131.6 | 16.1 | 130.4 | 15.1 | 0.48 | 123.0 | 21.1 | 123.3 | 22.0 | 0.91 |
| 36. Forward grip reach | 65.6 | 5.2 | 65.1 | 5.7 | 0.51 | 63.9 | 7.2 | 64.4 | 6.6 | 0.41 |

1.4. Ventilation System

The Ministry of Health states three main criteria for using natural ventilation in TB treatment rooms: ventilation rate, airflow direction, and air distribution or airflow pattern [2]. There are three ventilation methods: natural ventilation, mechanical ventilation, and mixed ventilation, where hybrid ventilation is a combined system of biological and mechanical systems. Treatment of TB patients should use natural ventilation with a combination of mechanical ventilation as recommended by the World Health Organization (WHO) [17]. In a study entitled Tuberculosis as a Primary Cause of Respiratory Failure Requiring Mechanical Ventilation, Penner stated that TB is one of the leading causes of respiratory failure [18]. Charles Penner found that hospitals that do not use a mechanical ventilation system have inferior treatment ability than hospitals that use a mechanical ventilation system [19]. However, he states that a mechanical ventilation system was proven to reduce the spread of infectious bacteria through the air. A mechanical ventilation system called a displacement system operates with a clean air strategy at a low velocity that enters the room through the vent at the bottom. Then actively and constantly, the infectious air is expelled through the top of the room to create a one-way ventilation flow. It can also achieve the essential criteria for ventilation in TB treatment rooms through optimal ventilation/natural ventilation performance, which relies heavily on natural ventilation components, and windows. Some aspects that must consider in applying ventilation are the orientation of the ventilation openings, the position of the ventilation openings, the dimensions of the ventilation openings, and the ventilation configuration.

1.5. Air Change per Hour (ACH)

The TBTR's ability to ventilate dramatically affects the transmission rates of TB. The number of fresh air changes acquired from outside the room for every hour and calculated using air change per hour (ACH). Higher ACH means a higher ability to dilute airborne pathogens, thus reducing the risk of airborne TB transmission. In the TB treatment room, the air exchange requirements from PPPI-TB are 12 times per hour [20]. Apart from PPI-TB, the ACH standard issued by the United States are 12 times per hour [21].

ASHRAE standards [22] stated that the minimum ACH treatment room is around 6 – 20 times per hour. Therefore, a room with a high air volume that is re-inhaled or does not experience a high volume of air exchange increases the risk of TB transmission to users in that room [23]. In addition, routine TB treatment can be ineffective if the air change in the DOTS (Directly Observed Treatment Shortcourse) room is insufficient [10]. Therefore, air change is essential for reducing TB transmission rates regarding TB treatment rooms. After conducting studies on TB, TB treatment, surveillance, anthropometry, and ventilation systems, it can produce an initial prototype design to develop a TB treatment room model.

2. RESEARCH METHOD

The method used was an experimental quantitative method which consists of several stages, namely:

1. Literature Data Search
The data collected is in theories and guidelines about TB and theories about ventilation systems.
2. Interview Data Collection
Interviews with experts: General Practitioners (Lieutenant Colonel CKM (K) dr. Virni Sagita Ismayawati, MARS; Pathology Specialist Doctor, dr. Brigitte Rina Aninda Sidharta, SpPK-K; Nurse, Sri Widayati, Amk and Dewi Ustaningsih, S.Kep .; Laboratory Officer, Diktia Sani Kisna Anita, Amd.
3. Simulation
The simulations are Computational Fluid Dynamics (CFD), done by Autodesk CFD software.

2.1. Objects

The object of study was the TBTR prototype, which was designed and developed following existing standards and requirements. The designed prototype was then analyzed by using Autodesk CFD. Analysis used Autodesk CFD for ventilation coverage (ventilation rate), airflow direction, and air distribution (pattern). These three elements are new fundamental variables in designing unique rooms for TB care.

2.2. Literature Review

Studies included literature about TB, TB patients' needs, TB in a humid tropical climate, and natural ventilation and TB. It carried out the literature review to identify and find general and specific criteria for unique TB care rooms to minimize TB transmission in humid tropical climates.

2.3. Prototype Exploration

According to the interview results, one of the problems with TB treatment rooms is limited land, which causes TB treatment rooms to be located more often in a critical location that does not meet the general requirements. Therefore, the exploration of the TBTR prototype in two stages: the space analysis developed based on the anthropometric approach and the study of the openings developed based on the criteria for TB treatment rooms that must achieve.

2.4. Computational fluid Dynamics (CFD) simulation

The Autodesk CFD simulation in three stages: (1) preprocessing, creating a prototype model using the Computer-Aided Design (CAD) format, (2) solving, the calculation process performed by Autodesk CFD, (3) postprocessing, data interpretation by Autodesk CFD in the form of figures and tables.

3. RESULTS AND DISCUSSION

Based on the activity analysis, the TBTR prototype divides into two zones. First, patients need a waiting room, sputum rooms, and medicine drinking rooms. Second, health workers need an examination room, consultation room, and sputum preparation room.

Table 2. Activity analysis
Source: Authors

| Num. | Subject | Amount of People | Activities | Room Requirements |
|--------------------------|---------------------|------------------|------------|--|
| Visitor / Patient | | | | |
| 1. | TB Suspect | 1 | | Sputum Room Medicine Room Consultation Room Waiting Room Wash Room |
| 2. | TB Patient | 1 | | Sputum Room Consultation Room Waiting Room Wash Room |
| 3. | TB-MDR Patient | 1 | | Check-up Room Medicine Room Waiting Room Consultation Room |
| 4. | Patient's Companion | 1 | | Waiting Room |
| Healthcare Staff | | | | |
| 4. | Nurse | 1 | | Waiting Room Check-up Room |
| 5. | Doctor | 1 | | Consultation Room Check-up Room |
| 6. | Laboratory Staff | 1 | | Sputum Room Sputum preparation Room |

3.1. Tuberculosis Treatment Room Prototype

Based on the general criteria and specific criteria identified, it becomes a reference for researchers to develop unique TB care room prototypes that can minimize TB transmission in health facilities in humid tropical climates. For example, use the ACH calculation to determine the room's ventilation amount.

According to the interviews with several health workers, one of the problems in TB treatment rooms at *Puskesmas* is the limited land, which causes TB treatment rooms to be more often located in critical locations and do not meet the general requirements of TB rooms. A vital place, for example, is a space squeezed by another, leaving one area of the room wall or two areas of the room wall which are potential for ventilation placement.

The TB treatment room prototype model was developed based on an anthropometric approach to obtain the most adequate and optimal size for TB patient care activities between health workers and TB patients. In addition, the TB prototype model was developed based on the criteria for TB treatment rooms that must achieve adequately. Autodesk CFD will then analyze the prototype model's ability to change the air to minimize the spread of *Mycobacterium tuberculosis* that causes TB in health facilities by referring to several existing general and specific criteria.

CFD media simulates fluid dynamic motion using the basics of moving fluid calculations. In addition, CFD simulations are relatively cheaper, and the research object's boundary conditions are easy to control, so, as a research method in developing alternative natural ventilation designs, use CFD simulations [24]. Simulations carried out a model with the following specifications:

Table 3. Prototype Model Specification
Source: Authors

| | |
|--------------------------------|--------------|
| Mechanic Ventilation Amount | 15 |
| Mechanic Ventilation Dimension | 30cm x 30cm |
| Natural Ventilation Amount | 2 |
| Natural Ventilation Dimension | 30cm x 170cm |
| ACH Standards | [20]–[22] |
| Wind Velocity | 1.5 m/s |

Schematic Prototype Model Design

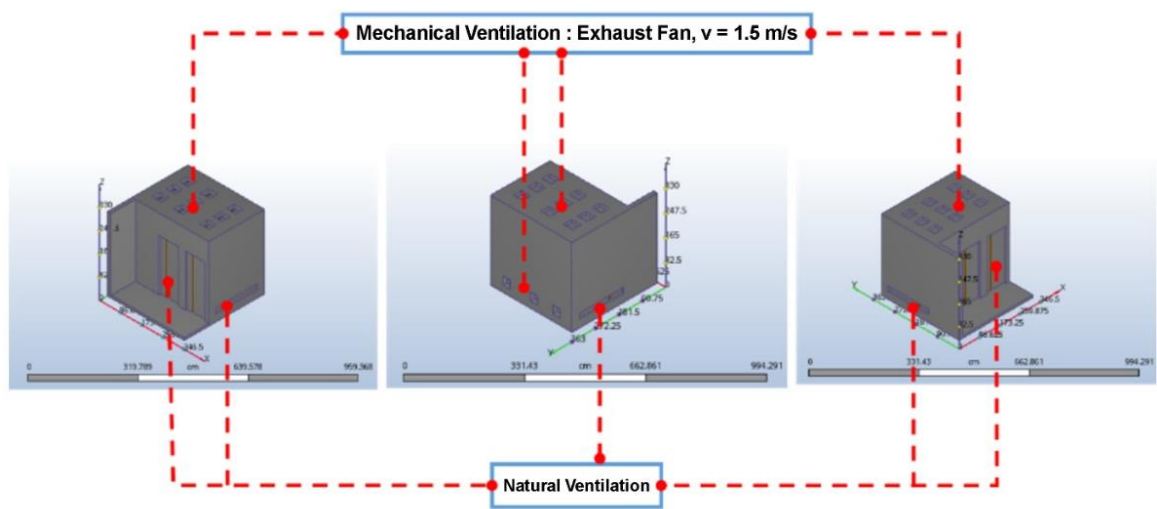

Floor Plan

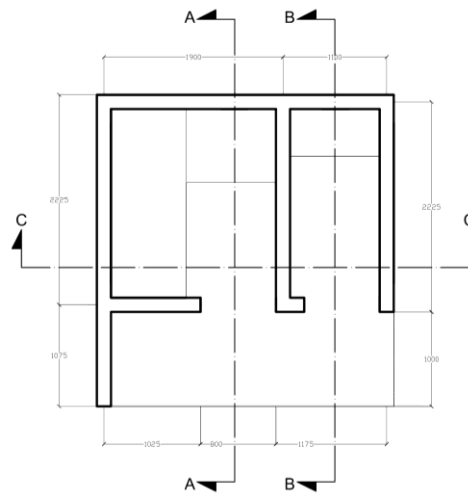

Section A - A

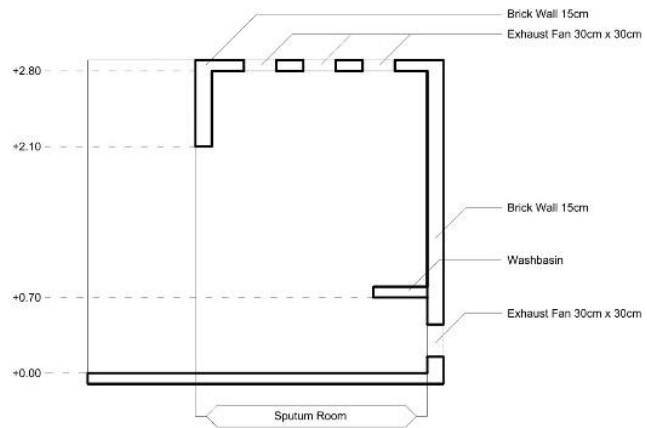

Section B - B

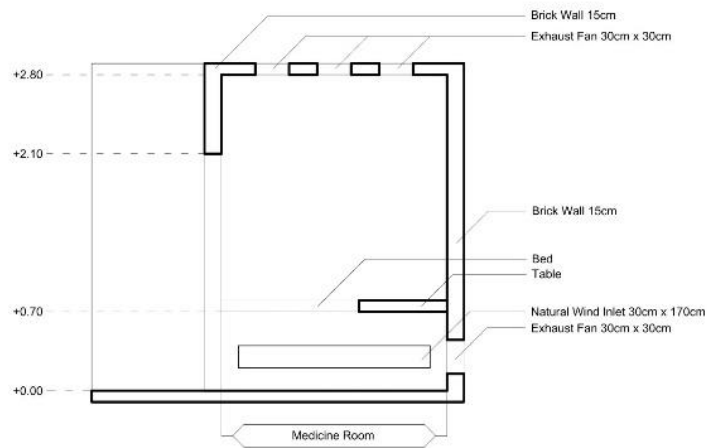

Section C - C

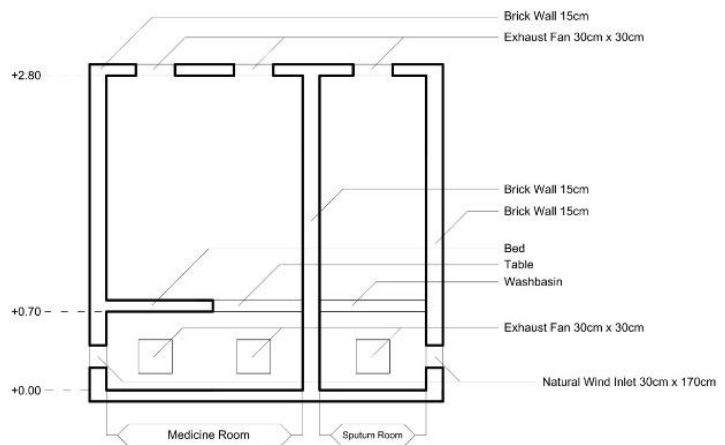

3.2. Ergonomic Analysis

The TBTR must accommodate all the activities of patients and health workers optimally. It must also consider the limited land in health facilities developing unique TB treatment rooms. Therefore, it is necessary to pay attention to the dimensions of the space according to its users' anthropometry to find sufficient and optimal space for a TBTR. The patient space includes a waiting room, a sputum room, and a medicine-taking room, and each area refers to the minimum size according to anthropometric data.

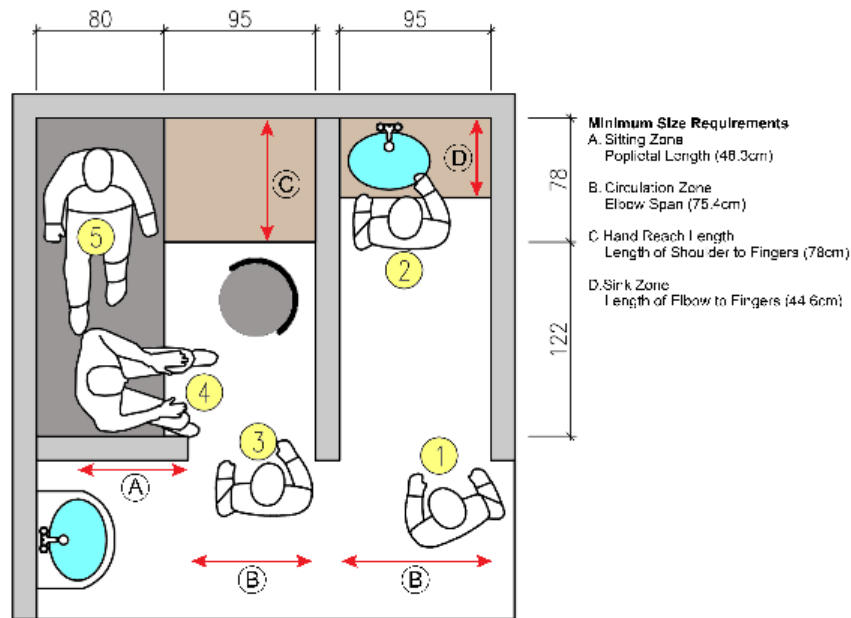

Figure 1. Analysis of Patient's Ergonomic Efficiency
Source: Authors

The sputum chamber consists of a circulation zone, a bathroom, and a sputum room. The washroom has a minimum width of 44.6 cm. An area for placing sputum is determined according to the arms reach from the shoulder of a TB patient or TB suspect, about 78 cm.

After collecting sputum samples, a TB patient or suspect moves to the medicine room. The circulation zone has a minimum width of about 75.4 cm, the width of the span between the elbows (elbow span). Before taking the drug, the TB patient or suspect receives consultation in a sitting position without blocking the circulation zone. The circulation zone considers The popliteal buttocks and the width of the patient's bed.

When taking medicine, the area needed is as far as a hand can reach to take the TB medicine. Many TB drugs react quickly and sometimes give side effects such as dizziness and weakness, especially medications for MDR-TB. The patient who takes TB drugs requires a bed to get rid of the side effects of the drug by lying down; the minimum length of the bed is about 158.9 cm to 200 cm with a minimum width to accommodate the hand's reach, which is about 78 cm.

The room for health workers consists of a room for consultation, a circulation room, and a sputum room for preparing sputum. The consultation room must be able to accommodate health workers. Both doctors and medical staff are in charge of providing directions for TB patients or TB suspects. The laboratory personnel uses the sputum preparation room to prepare sputum samples, which will then examine in the laboratory.

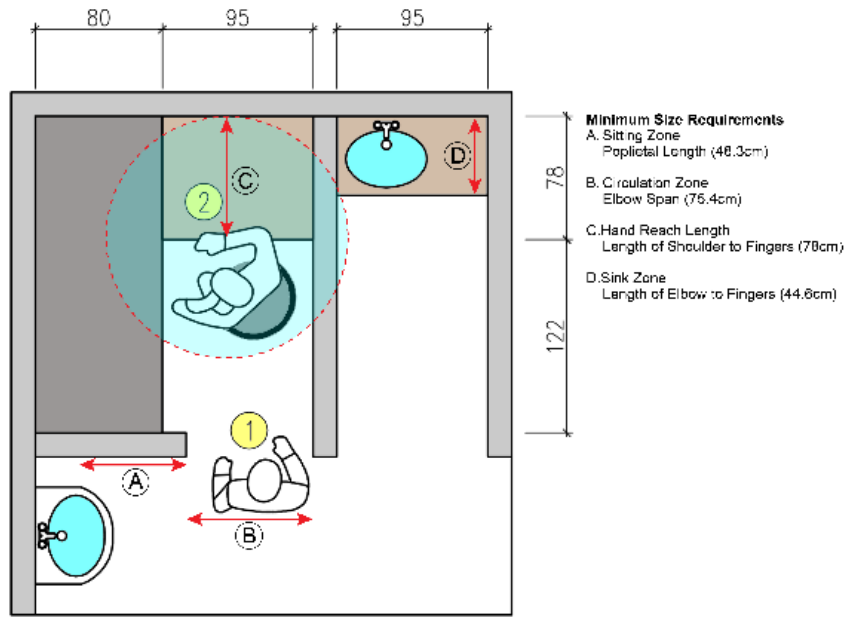

Figure 2. Analysis of Healthcare Staff's Ergonomic Efficiency
Source: Authors

The doctor or medicine staff gives TB patients or suspects directions to take TB drugs in the medicine room. The width of the desk for health workers refers to the minimum size of the minimum reach of an adult hand, which is about 78 cm. The distance between health workers and TB patients or suspects refers to the length of the health workers' hands. The circulation zone has a minimum width of about 75.4 cm, the span between the elbows.

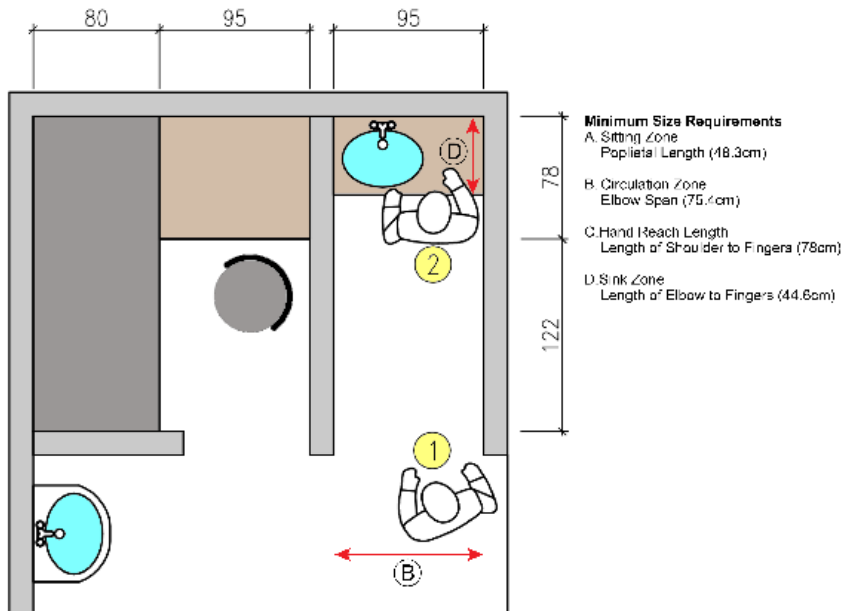

Figure 3. Analysis of Laboratory Staff's Ergonomic Efficiency
Source: Authors

Laboratory personnel enters the sputum room after a TB patient or suspect collects sputum and leaves it in the sputum room. The laboratory staff then prepares the sputum for testing in the laboratory. The zone required to prepare sputum is the same as the zone required for the sink, with a minimum width of about 44.6 cm.

3.3. Ventilation Analysis with Autodesk CFD

Analysis was done on the prototype model mentioned above, using *Autodesk CFD*. The results are as shown in the discussion below.

Section A – A Analysis

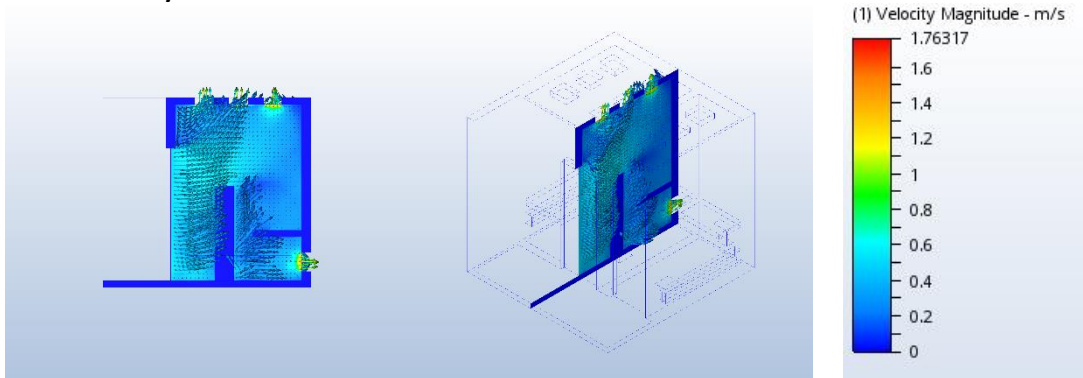

Figure 4. Section A – A (Medicine Room) Analysis Using Autodesk CFD
Source: Authors

The medicine room accommodates the area of the patient who is taking medication and lying down/sleeping. In sections A – A, the medicine room's airflow of 80 cm above the floor (patient's bed) constantly moves toward the ceiling at about 0.2 m/s to 0.6 m/s. The constant air movement allows TB bacilli in the droplets released by TB patients to draw to the top of the room before being transmitted to health workers or other users in the medicine room. At a height above 80 cm, the infectious droplets are constantly moving upwards and being dumped outside the room, reducing the risk of transmission to health workers.

The medicine room also accommodates the work area of health workers. In the work area, the airflow moves from 0.2 m/s to 0.6 m/s with an altitude of 80 cm until 250 cm from the floor. In the work area of health workers, a constant flow of air to the ceiling prevents the transmission of TB bacilli from TB patients.

In the prototype model, mechanical ventilation in the form of exhaust fans at the bottom of the room causes humid air. This moist air contains microorganisms other than TB bacteria at the height of about 40 cm to be removed from the room and does not cause nosocomial infections for users but is still safe for people around the treatment room.

Section B – B Analysis

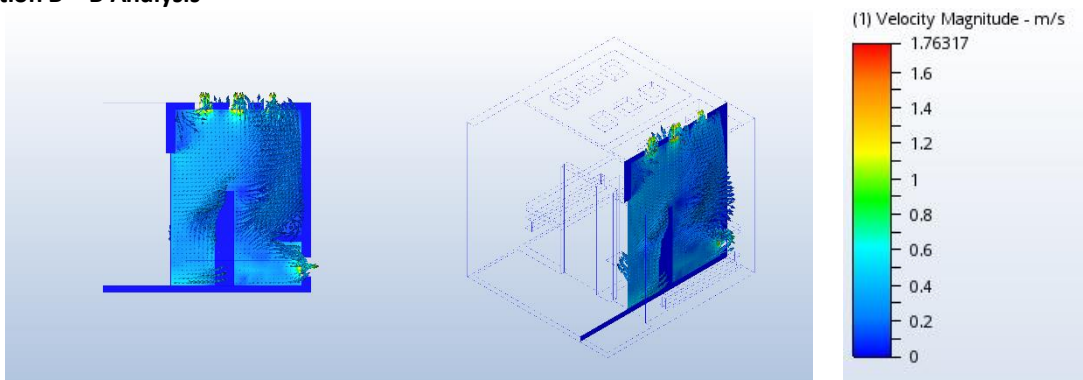

Figure 5. Section B - B (Sputum Room) Analysis Using Autodesk CFD
Source: Authors

The sputum room is infectious with sputum and droplet collection activities by TB patients or suspects. The sputum room requires airflow conditioning to quickly and thoroughly replace the air in the room. The airflow in the sputum collection area is divided into two, namely, moving upwards and downwards. The upward flow of air starts from 80 cm above the floor with a speed of about 0.1 m/s to 0.4 m/s. The airflow at the bottom moves from a rate of 0.1 m/s to 0.6 m/s constantly out of the room.

Section C – C Analysis

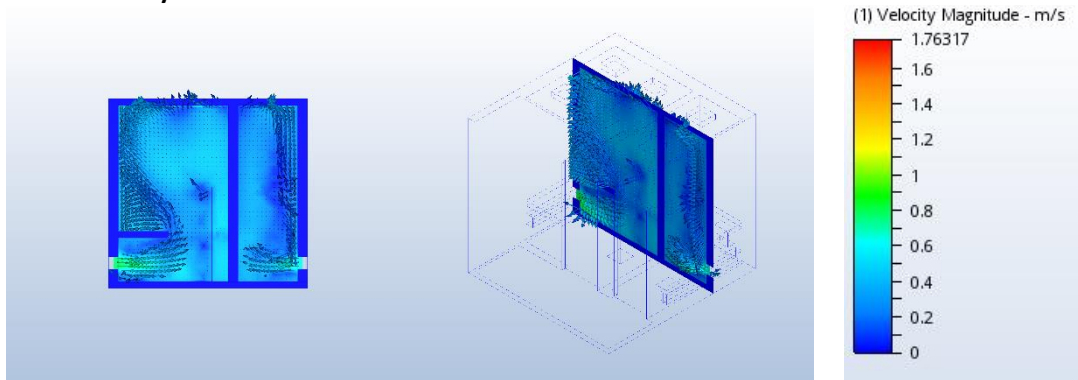

Figure 6. Section C - C (Medicine and Sputum Room) Analysis Using Autodesk CFD
Source: Authors

Airflow in the prototype model has two parts: air moving upwards and air moving at the bottom. The inlet of natural ventilation at the bottom of the room supplies air for the room to get fresh air from outside the room. The exhaust fan at the top moves air from 80 cm above the floor out of the room. The exhaust fan at the bottom of the chamber releases humid air at a speed of up to 0.6 m/s. The airflow in the prototype model had achieved a constant wind velocity of 0.2 m/s to 0.6 m/s, surpassing the minimum standard of more than 0.1 m/s. The flow direction of air inside the prototype model meets the requirement stated by the standard, which is flowing vertically. Therefore, the TBTR prototype already meets the criteria stated in the standards.

3.4. Air Changes per Hour (ACH)

The formula used to calculate ACH is as below

$$ACH = \frac{\text{Area of Ventilation} \times \text{Wind Velocity}}{\text{Room's Volume}} \times 3600 \text{ seconds}$$

The number obtained must be equal to or surpassing the requirements stated by the PPI-TB, CDC, and ANSI/ASHRAE/ ASHE 170-2013 [20]–[22], which is as stated below:

Table 4. ACH minimum Standards

| PPI-TB | Centers for Disease Control and Prevention (CDC) | ANSI/ASHRAE/ASHE 170-2013 |
|--------|--|---------------------------|
| 12 | 12 | 6 - 20 |

Table 5. ACH at the TBTR prototype

| Room | Room Area Size (m ²) | Height (m) | Room's Volume (m ³) | Wind Velocity (m/s) | Ventilation Area Size (m ²) | ACH |
|---------------|----------------------------------|------------|---------------------------------|---------------------|---|-------------|
| Medicine Room | 3.5 | 2.8 | 9.8 | 0.2 | 1.06 | 77.87755102 |
| Sputum Room | 1.9 | 2.8 | 5.32 | 0.2 | 0.7 | 94.73684211 |

The ACH in the TBTR prototype surpassed the requirements stated by PPI-TB, CDC, and ANSI/ASHRAE/ASHE. The average ACH in the TBTR prototype is 77-94 times the minimum wind velocity.

4. CONCLUSION

Based on the results of the analysis and discussion in the previous chapter, conclusions can be drawn, including:

There are two Tuberculosis treatments, collecting and researching sputum or sputum preparations and drinking ATD (anti-Tuberculosis drug), supervised by medical staff. The particular treatment room has two rooms: the medicine drinking room and the sputum room with the subjects, namely healthcare staff and TB patients (or TB suspects). Ergonomically, the minimum dimensions of a practical medicine-taking room are 175 cm x 200 cm consisting of the sitting zone, circulation zone, and hand reach zone. The minimum sizes of the functional sputum space are 95 cm x 200 cm with a circulation zone and a sink zone. The TBTR prototype shows the airflow has two parts: the air moving upwards and the air moving at the bottom. Air containing MTB bacteria moves out of the room at 0.1-0.4 m/s, while the humid air at the bottom of the room is constantly expelled at a rate of 0.1-0.6 m/s, thereby reducing the risk of nosocomial infection in the treatment room.

With a pre-simulated ventilation system, the TBTR is good enough to suppress the transmission of the Mycobacterium tuberculosis bacteria in the room. Test with CFD simulation is sufficient to represent the condition of the TBTR prototype. Autodesk CFD software is also reliable as a fluid simulation testing tool in the room. Empirical testing is needed to validate the research results. The TBTR prototype is a good solution for many developing countries in humid climates tropical with Tuberculosis problems.

REFERENCES

- [1] R. Reviono, W. Setianingsih, K. E. Damayanti, and R. Ekasari, "The dynamic of tuberculosis case finding in the era of the public-private mix strategy for tuberculosis control in Central Java, Indonesia," *Glob. Health Action*, vol. 10, no. 1, 2017, doi: 10.1080/16549716.2017.1353777.
- [2] Depkes, *Pedoman Pencegahan Dan Pengendalian Infeksi Tuberkulosis Di Fasilitas Pelayanan Kesehatan*. Jakarta: Kementerian Kesehatan Republik Indonesia Direktorat Bina Upaya Kesehatan, 2012.
- [3] C. Dewi, L. Barclay, M. Passey, and S. Wilson, "Improving knowledge and behaviours related to the cause, transmission and prevention of Tuberculosis and early case detection: A descriptive study of community led Tuberculosis program in Flores, Indonesia," *BMC Public Health*, vol. 16, no. 1, pp. 1–13, 2016, doi: 10.1186/s12889-016-3448-4.
- [4] A. Probandari *et al.*, "The path to impact of operational research on tuberculosis control policies and practices in Indonesia," *Glob. Health Action*, vol. 9, no. 1, 2016, doi: 10.3402/gha.v9.29866.
- [5] C. Basri, K. Bergström, W. Walton, A. Surya, J. Voskens, and F. Metha, "Sustainable scaling up of good quality health worker education for tuberculosis control in Indonesia: A case study," *Hum. Resour. Health*, vol. 7, pp. 1–10, 2009, doi: 10.1186/1478-4491-7-85.
- [6] R. A. Ahmad *et al.*, "Diagnostic work-up and loss of tuberculosis suspects in Jogjakarta, Indonesia," *BMC Public Health*, vol. 12, no. 1, p. 132, 2012, doi: 10.1186/1471-2458-12-132.
- [7] C. Y. Aditama, *Tuberkulosis Paru.: Masalah dan penanggulangannya*. Jakarta: UI Press.
- [8] A. Catanzaro, "Nosocomial Tuberculosis 12 ANTONINO CATANZARO With the technical assistance of Sandra Emerson and Ellen Logue," pp. 559–562, 1981.
- [9] N. Ahmed and S. E. Hasnain, "Molecular epidemiology of tuberculosis in India: Moving forward with a systems biology approach," *Tuberculosis*, vol. 91, no. 5, pp. 407–413, 2011, doi: 10.1016/j.tube.2011.03.006.
- [10] E. A. Nardell, "Indoor environmental control of tuberculosis and other airborne infections," *Indoor Air*, vol. 26, no. 1, pp. 79–87, 2016, doi: 10.1111/ina.12232.
- [11] H. Chu *et al.*, "Risk of tuberculosis among healthcare workers in an intermediate-burden country: A nationwide population study," *J. Infect.*, vol. 69, no. 6, pp. 525–532, 2014, doi: 10.1016/j.jinf.2014.06.019.
- [12] Depkes, *Pedoman Nasional Pengendalian Tuberkulosis*. Jakarta: Kementerian Kesehatan Republik Indonesia Direktorat Jenderal Pengendalian Menular dan Penyehatan Lingkungan Permukiman, 2014.
- [13] M. Girsang, "Kesalahan-kesalahan dalam Pemeriksaan Sputum BTA pada Program Penanggulangan TV terhadap beberapa Pemeriksaan dan Identifikasi Penyakit TBC," *Jakarta Media Litbang Kesehat.*, vol. IX, no. 3, 1999.
- [14] Atmosukarto and S. Soewasti, "Pengaruh Lingkungan Pemukiman dalam Penyebaran Tuberkulosis," *Jakarta Media Litbang Kesehat.*, vol. IX, no. 4, 2000.
- [15] N. I. P. Sari, N. M. Mertaniasih, Soedarsono, and F. Maruyama, "Application of serial tests for Mycobacterium tuberculosis detection to active lung tuberculosis cases in Indonesia," *BMC Res. Notes*, vol. 12, no. 1, pp. 1–6, 2019, doi: 10.1186/s13104-019-4350-9.
- [16] M. Hartono, "Indonesian anthropometry update for special populations incorporating Drillis and Contini

- revisited," *Int. J. Ind. Ergon.*, vol. 64, pp. 89–101, 2018, doi: 10.1016/j.ergon.2018.01.004.
- [17] Kementerian Kesehatan Republik Indonesia, *Peraturan Menteri Kesehatan Republik Indonesia Nomor 27 Tahun 2017 Tentang Pedoman Pencegahan Dan Pengendalian Infeksi Di Fasilitas Pelayanan Kesehatan*. Jakarta, 2017.
- [18] C. Penner, D. Roberts, D. Kunimoto, J. Manfreda, and R. Long, "Tuberculosis as a primary cause of respiratory failure requiring mechanical ventilation," *Am. J. Respir. Crit. Care Med.*, vol. 151, no. 3 I, pp. 867–872, 1995, doi: 10.1164/ajrccm.151.3.7881684.
- [19] J. W. Tang, Y. Li, I. Eames, P. K. S. Chan, and G. L. Ridgway, "Factors involved in the aerosol transmission of infection and control of ventilation in healthcare premises," *J. Hosp. Infect.*, vol. 64, no. 2, pp. 100–114, 2006, doi: 10.1016/j.jhin.2006.05.022.
- [20] Kementerian Kesehatan Republik Indonesia Direktorat Bina upaya Kesehatan Jakarta, *Pedoman Pengendalian TB di Fasyankes*. Jakarta, 2012.
- [21] U.S. Department of Health & Human Services, "Centers for Disease Control and Prevention." <https://www.cdc.gov/>.
- [22] ASHRAE, "ASHRAE." <https://www.ashrae.org/technical-resources/standards-and-guidelines/standards-interpretations/interpretations-for-standard-170-2013>.
- [23] C. M. Issarow, N. Mulder, and R. Wood, "Environmental and social factors impacting on epidemic and endemic tuberculosis: A modelling analysis," *R. Soc. Open Sci.*, vol. 5, no. 1, 2018, doi: 10.1098/rsos.170726.
- [24] M. Santamouris and F. Allard, *Natural Ventilation in Buildings: A Design Handbook*. London: James & James, 1998.

BIOGRAPHIES OF AUTHORS

| | |
|--|---|
| Wisdom Sandjaya Papendang; ST., MT. | Received his ST. and MT. in Architectural Engineering from Atma Jaya University Yogyakarta Faculty of Engineering (2016-2019). Currently works as an Principial Architect at Trinita Widi Anoma Consultant. Major research interests include computational design, building science, and sustainable environment development. |
| Samuel Yudhatama | Received his S.Ars in Architecture from Universitas Atma Jaya Yogyakarta, Indonesia (2016 – 2020), currently taking on the course of Master degree of Digital Architecture on Universitas Atma Jaya Yogyakarta. Major research interests include architecture, science, and technology. |